

*Delivering Actionable Intelligence
through Data Management and Collaboration with HanPrism*

Korea South-East Power

Korea South-East Power Company (KOEN) is one of the largest energy companies in South Korea. KOEN generates electricity for metropolitan areas and southern Korean and generates approximately 10% of South Korea's annual net electricity.

Challenges

As systems and equipment in process plants become more complex and sophisticated, gaining actionable intelligence from the vast amount of generated data has become one of the key success factors in the industry. Extracting accurate and meaningful information from the data helps KOEN achieve operational excellence. KOEN needed a solution that provided actionable intelligence for plant operation, business, and enterprise decisions. KOEN had several enterprise-wide issues.

1. Enterprise-Wide Data Management & Integration

KOEN needed a solution that offered enterprise-wide data management and integration. KOEN did not have an adequate software to manage and integrate vast amounts of data generated from its many plants and locations. Since the volume of the data was tremendous and the data sources were diverse, it was very difficult to manage and integrate the data.

2. Lack of Data Infrastructure

KOEN needed a data infrastructure for its headquarters' integrated control and monitoring center. KOEN's headquarters and its plants needed a data infrastructure to help them communicate and collaborate to generate actionable intelligence.

3. Lack of Collaboration

In order to make a strategic business decision, executives need to collaborate with the field level to gain each other's unique insights. However, KOEN did not have an optimized solution to provide such a collaborative ground for their business decisions. KOEN's business decisions often included only managerial and executive insights, rather than encompassing the entire enterprise insights, including those from the field level.

There are some solutions that manage operational data for operators and managers; however, not many of them successfully provide the collaborative ground for members to gain truly actionable intelligence.

HanPrism

In 2011, KOEN headquarters and plants installed HanPrism. HanPrism is the most precise and fastest solution for process plants to draw actionable intelligence from vast and widely dispersed data. HanAra implements an intelligence-centric approach to historian software, creating a powerful and innovative data infrastructure. This enables KOEN to utilize and increasing pool of data to achieve operation excellence.

Benefits

1. Efficient Data Management & Integration

Operational data from each plant was collected and integrated in KOEN headquarters' HanPrism server. Although nearly 35% of the plants are geographically distant from the headquarters, thanks to HanPrism, KOEN easily collects and integrate all the data from each plant's server to improve the reliability and availability.

2. Easy Data Analysis and Sharing

Collaboration among the organization is much improved because of HanPrism. With a proxy server mediating data transmission, headquarters and each plant can now quickly query and retrieve data without slowing down the server's performance. With HanPrism's outstanding analysis and visualization tools, KOEN can share meaningful data whenever and wherever they want. This provides an optimal environment for collaboration, thus achieving actionable intelligence.

3. Actionable Intelligence through Analysis Tools

HanPrism is a highly flexible software that provides a bridge to external applications. Data processed by HanPrism constantly delivers real-time and historical data and collaborates with ERP, predictive analytics systems, and performance monitoring systems. KOEN has been successful in gaining actionable intelligence that leads to effective business decisions.

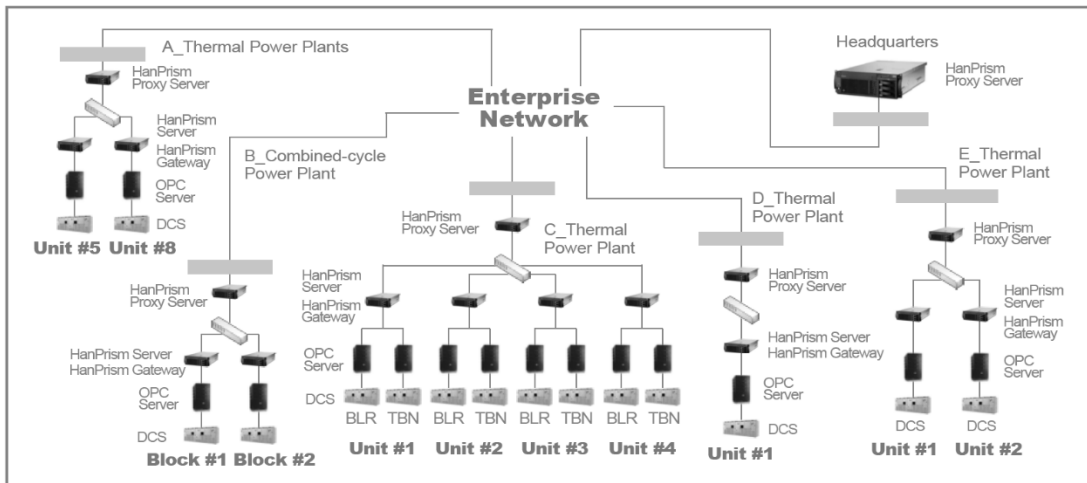

Challenges

- Data stored separately across systems in multiple locations
- Necessary data infrastructure to communicate and collaborate at integrated control and monitoring center
- Business decision based on managerial or executive insight, not the entire organization's insight

HanPrism

- Collect data from diverse data sources and store in a central server
- Monitor real-time data for multiple plants from a centralized location
- Quickly check, analyze and share data anywhere and at any time

Benefits

- Reduce cost of managing and maintaining multiple data sources by building a stable centralized historian server
- Prevent unplanned shutdowns by monitoring operations
- Analyze long-term data with powerful trend tools within a second instead of minutes